



PATIENT & CAREGIVER EDUCATION

How To Use an Emergency Glucagon Injection Kit

This information explains what an emergency glucagon injection kit is and how to use it. It also has instructions for caregivers who may need to give an emergency glucagon treatment.

What is an emergency glucagon injection kit?

An emergency glucagon injection kit is an intramuscular (IN-truh-MUS-kyoo-ler) medication. An intramuscular injection (shot) goes directly into the muscle. Emergency glucagon injection kits do not come ready to use like some other treatments. You will need to get it ready right before you use it.

An emergency glucagon injection can help raise your blood glucose (blood sugar) level quickly. This can help keep you safe if you have hypoglycemia (low blood sugar). It's important to treat hypoglycemia right away. Read *About Hypoglycemia (Low Blood Sugar)* (www.mskcc.org/pe/low_blood_sugar) for more information.

An emergency glucagon injection kit (see Figure 1) includes:

- A vial with glucagon powder.
- A syringe with sterile water.

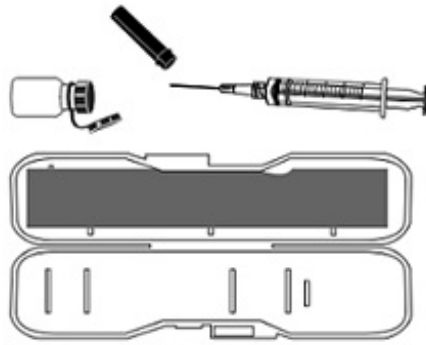

Figure 1. Emergency glucagon injection kit

How to give an emergency glucagon injection

To give the injection, you'll need the glucagon emergency kit and an alcohol swab.

Follow these steps:

1. Open the glucagon kit. There may be pictures on the inside of the plastic case or on a paper insert. Read and follow the instructions that come with the kit.
2. Take the cap off of the glass vial with the glucagon powder (see Figure 2).



Figure 2. Remove the plastic cap

3. Pick up the prefilled syringe and remove the needle cover.

4. Push the needle into the center of the rubber stopper. Slowly push down on the syringe plunger to inject all the liquid into the glass vial (see Figure 3). Do not remove the needle from the vial.



Figure 3. Injecting the diluting fluid into the glucagon vial

5. Gently shake or roll the vial to mix it. Hold the vial and syringe in one hand with the vial on top and syringe on bottom (see Figure 4). Mix until all the powder is completely dissolved.

The solution should be clear and colorless. You may see bubbles from mixing. This is normal. **Do not use the medication if it's cloudy or you see solid particles that do not go away after mixing. Call 911 right away.**



Figure 4. Mix the glucagon powder with the liquid

6. Keep holding the vial and syringe with the vial on top and the syringe on bottom. Move the tip of the needle towards the bottom of the vial near the rubber stopper (see Figure 5).

Pull back on the plunger of the syringe to fill the syringe with all the medication in the vial. If there is air at the top of the syringe, gently push the plunger to remove it.



Figure 5. Fill the syringe with glucagon mixture

7. Choose an injection site. You can inject glucagon into the top of the thigh (upper leg), outer buttock area, or upper outer arm. Clean the site with an alcohol swab, if you have one.
8. Inject the glucagon into the muscle. Insert the needle into the skin in one quick motion at a 90-degree angle (straight up and down). Use your thumb to push the plunger all the way down to inject the medication (see Figure 6).

Only inject the glucagon through the person's clothing if you cannot remove the clothing from the injection site quickly.

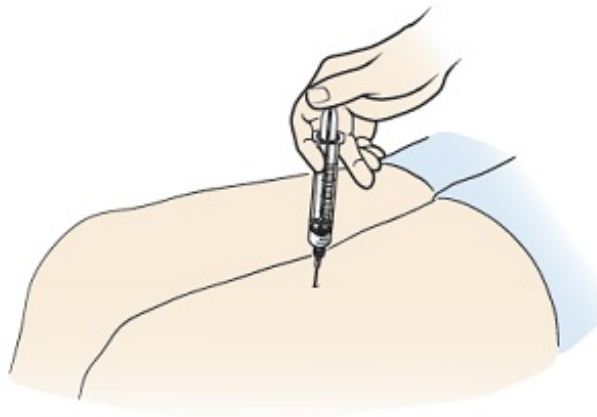

Figure 6. Inject the emergency glucagon into the muscle

9. When the syringe is empty, pull it straight out of the skin.

What to do after giving someone an emergency glucagon treatment



After the injection, roll the person onto their side. Glucagon sometimes causes people to vomit, turning them onto their side will help keep them from choking. Then call 911 for an ambulance.

Check the person's blood sugar level 15 minutes after the treatment. An unconscious person will usually wake up within 15 minutes.

If the person is awake within 15 minutes:

- If their blood sugar is still below 70 mg/dL, follow the rule of 15/15.
- If their blood sugar is 70 mg/dL or higher, have them eat a snack or next meal within one hour. This will help stop their blood sugar from dropping again. A small snack may include one of the following:
 - Peanut butter or cheese with 4 to 5 crackers.
 - Half of a sandwich and 4 ounces of milk.
 - A single-serve container of Greek yogurt.

If the person is not awake after 15 minutes:

- Give them a second emergency treatment, if they have one.
- Wait for emergency services to arrive.

How to safely get rid of an emergency glucagon treatment kit

Each emergency glucagon treatment device should only be used once. After you use it, throw it away. If the person needs another treatment, use a new device.

Do not throw needles or syringes directly into the trash or flush them down the toilet. Put them into a sharps container or a hard, plastic container with a screw top lid, such as a laundry detergent bottle. Label the bottle by writing “**Home Sharps: not for recycling**” on it. Read *How to Store and Get Rid of Your Home Medical Sharps*

(www.mskcc.org/pe/store_get_rid_sharps) for more information.

If you have questions or concerns, contact your healthcare provider. A member of your care team will answer Monday through Friday from 9 a.m. to 5 p.m. Outside those hours, you can leave a message or talk with another MSK provider. There is always a doctor or nurse on call. If you're not sure how to reach your healthcare provider, call 212-639-2000.

For more resources, visit www.mskcc.org/pe to search our virtual library.

How To Use an Emergency Glucagon Injection Kit - Last updated on July 17, 2023
All rights owned and reserved by Memorial Sloan Kettering Cancer Center